

HIGH END SYSTEMS

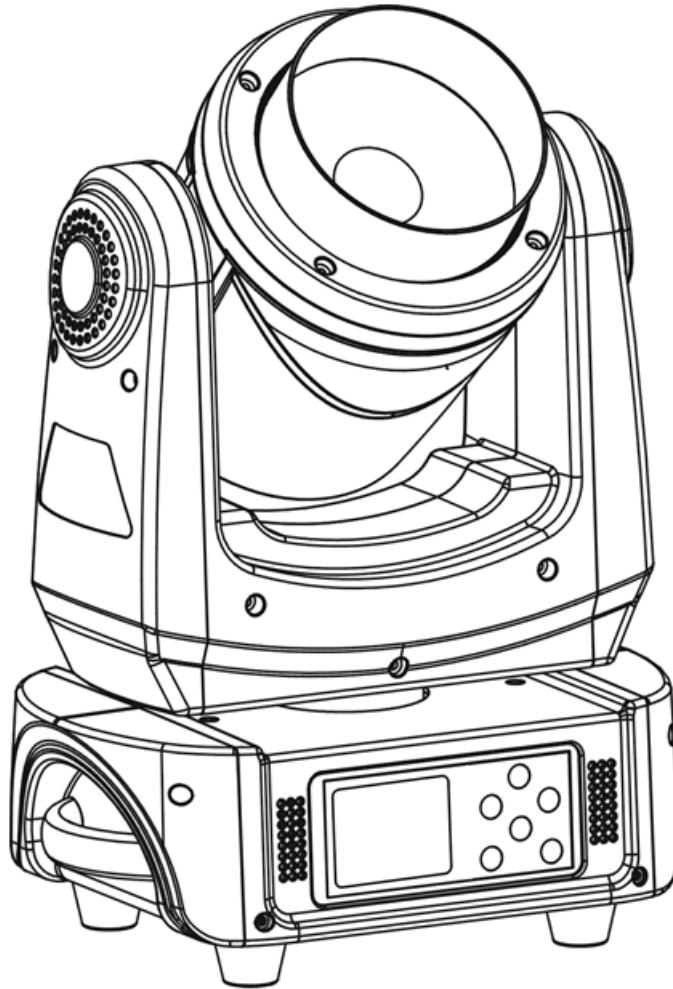

User Manual



Uno

Version 1.0.1

Table of Contents

Welcome.....	3
Contacting High End Systems.....	4
Patents.....	7
Warranty Information.....	9
Important Safety Information.....	10
Fixture Overview.....	11
Features.....	12
Safety Considerations.....	13
General Guidelines.....	14
Installation Instructions.....	15
Technical Specifications.....	16
Mounting Instructions.....	17
DMX Control Connections.....	18
DMX Start Address.....	19
DMX termination.....	19
Control Board.....	20
Control Board Functions.....	21
Preset, Programming and Playback.....	26
DMX Protocol.....	29
Error Codes.....	33

Welcome

Notice

© High End Systems Inc., 2017, All Rights Reserved

Information and specifications in this document are subject to change without notice. High End Systems assumes no responsibility or liability for any errors or inaccuracies that may appear in this manual. Trademarks used in this text: High End Systems is a registered trademark. Wholehog, intellaspot, Internal Effects, the High End Systems globe logo, and the Hog logo are trademarks of High End Systems, Belden is a registered trademark of Belden, Inc. Other trademarks and trade names may be used in this document to refer to either the entities claiming the marks and names or their products. High End Systems disclaims any proprietary interest in trademarks and trade names owned by others.

Contacting High End Systems ®

Sales Department

High End Systems, Inc.

2105 Gracy Farms Lane

Austin, TX 78758 USA

voice:512.836.2242

fax:512.837.5290

Toll Free: 800.890.8989

Customer Service

High End Systems, Inc.

2105 Gracy Farms Lane

Austin, TX 78758 USA

voice:800.890.8989

fax: 512.834.9195

toll free: 800.890.8989

email: support@highend.com

World Wide Web

<http://www.highend.com>

HIGH END SYSTEMS



an Ξ TC. Company

Declaration of Conformity

Manufacturer's name: HAO YEANG ELECTRONIC CO., LTD
Manufacturer's address: No. 109, HaiYong Road, GuanNanYoung Industry Districe, Shiji Town
DanYu Zone, GuanZhou City, China
Distributor's name: High End Systems
Distributor's address: 2105 Gracy Farms Lane
Austin, Texas 78758 USA
Product Name: UNO
Product Options: All

We hereby declare that the above referenced product complies with the essential requirements of Council Directives 2004/108/EC (EMC), 2006/95/EC (LVD) and 2011/65/EC (RoHS) .

Safety: EN 60598-1: 2008 + A11 (2009)
EN 60598-2-17: 1989 A1-A3 (1993)

EMC: Emission: EN 55022 (2010)
EN 61000-3-2 (2006) + A1 (2009) + A2 (2009)
EN 61000-3-3 (2008)

Immunity:EN 55024 (2010)

ROHS:	Restricted Substances	Maximum Concentration Value (by weight in homogeneous material)
	Cadmium (Cd)	0.01%
	Lead (Pb)	0.1%
	Mercury (Hg)	0.1%
	Hexavalent Chromium (Cr VI)	0.1%
	Polybrominated Biphenyl (PBB)	0.1%
	Polybrominated Diphenyl Ethers (PBDE)	0.1%

Kenneth S. Hansen

Compliance Engineer
April 4, 2016

FCC Information

This equipment has been tested and found to comply with the limits for a Class A digital device, pursuant to part 15 of the FCC rules. These limits are designed to provide reasonable protection against harmful interference when the equipment is operated in a commercial environment. This equipment generates, uses, and can radiate radio frequency energy and, if not installed and used in accordance with the instruction manual, may cause harmful interference to radio communications. Operation of this equipment in a residential area is likely to cause harmful interference, in which case the user will be required to correct the interference at his own expense.

Patents

This High End Systems product is protected by patents and pending patent applications.

Patents owned or licensed by High End Systems include:

US 4,392,187; US 4,602,321; US 4,688,161; US 4,701,833; US 4,709,311; US 4,779,176; US 4,800,474; US 4,962,687; US 4,972,306; US 4,980,806; US 5,010,459; US 5,031,078; US 5,073,847; US 5,078,039; US 5,186,536; US 5,209,560; US 5,278,742; US 5,282,121; US 5,307,295; US 5,329,431; US 5,331,822; US 5,367,444; US 5,402,326; US 5,414,328; US 5,426,576; US 5,430,629; US 5,432,691; US 5,454,477; US 5,455,748; US 5,502,627; US 5,506,762; US 5,515,254; US 5,537,303; US 5,545,951; US 5,588,021; US 5,590,954; US 5,590,955; US 5,640,061; US 5,647,662; US 5,691,886; US 5,702,082; US 5,728,994; US 5,758,955; US 5,758,956; US 5,769,527; US 5,769,531; US 5,774,273; US 5,788,365; US 5,794,881; US 5,795,058; US 5,798,619; US 5,806,951; US 5,812,596; US 5,823,661; US 5,825,548; US 5,828,485; US 5,829,868; US 5,857,768; US 5,882,107; US 5,921,659; US 5,934,794; US 5,940,204; US 5,945,786; US 5,953,151; US 5,953,152; US 5,969,485; US 5,980,066; US 5,983,280; US 5,984,248; US 5,986,201; US 6,011,662; US 6,029,122; US 6,048,080; US 6,048,081; US 6,054,816; US 6,057,958; US 6,062,706; US 6,079,853; US 6,126,288; US 6,142,652; US 6,142,653; US 6,172,822; US 6,175,771; US 6,188,933; US 6,208,087; US 6,219,093; US 6,220,730; US 6,241,366; US 6,249,091; US 6,255,787; US 6,256,136; US 6,261,636; US 6,278,542; US 6,278,545; US 6,278,563; US 6,288,828; US 6,326,741; US 6,327,103; US 6,331,756; US 6,346,783; US 6,421,165; US 6,430,934; US 6,459,217; US 6,466,357; US 6,502,961; US 6,515,435; US 6,523,353; US 6,536,922; US 6,538,797; US 6,545,586; US 6,549,324; US 6,549,326; US 6,563,520; US 6,565,941; US 6,570,348; US 6,575,577; US 6,578,991; US 6,588,944; US 6,592,480; US 6,597,132; US 6,600,270; US 6,601,974; US 6,605,907; US 6,617,792; US 6,621,239; US 6,622,053; US 6,635,999; US 6,648,286; US 6,664,745; US 6,682,031; US 6,693,392; US 6,696,101; US 6,719,433; US 6,736,528; US 6,771,411; US 6,775,991; US 6,783,251; US 6,801,353; US 6,812,653; US 6,823,119; US 6,865,008; US 6,866,390; US 6,866,402; US 6,866,451; US 6,869,193; US 6,891,656; US 6,894,443; US 6,919,916; US 6,930,456; US 6,934,071; US 6,937,338; US 6,955,435; US 6,969,960; US 6,971,764; US 6,982,529; US 6,988,805; US 6,988,807; US 6,988,817; US 7,000,417; US 7,011,429; US 7,018,047; US 7,020,370; US 7,033,028; US 7,048,838; US 7,055,963; US 7,055,964; US 7,057,797; US 7,073,910; US 7,078,869; US 7,092,098; US 7,119,902; US 7,161,562; US 7,175,317; US 7,181,112; US 7,206,023; US 7,210,798; US 7,253,942; US D347,113; US D350,408; US D359,574; US D360,404; US D365,165; US D366,712; US D370,080; US D372,550; US D374,439; US D377,338; US D381,740; US D409,771; AT E169413; CA 2142619; CA 2145508; CA 2245842; DE 22588.4-08; DE 621495; DE 655144; DE 69320175.4; DE 69322401.0; DE 69331145.2; DE 69525856.7; DE 69734744.3; DE 797503; DK 0655144; DK 1447702; EP 0475082; EP 0621495; EP 0655144; EP 0662275; EP 0767398; EP 0797503; EP 0969247; EP 1447702; ES 0621495; FR 0621495; FR 0655144; FR 0662275; FR 1447702; GB 2043769B; GB 2055842B; GB 2283808B; GB 2290134B; GB 2291814B; GB 2292530B; GB 2292896B; GB 2294909B; GB 2295058B; GB 2303203B; GB 2306887B; GB 2307036B; GB 2316477B; IE 0621495; IT 034244BE; 2005; IT 0621495; IT 0655144; JP 3495373; JP 3793577; NL 0621495; NL 0797503; NL 0969247; UK 0621495; UK 0655144; UK 0662275; UK 0797503; UK 0969247; UK 1447702;

Product Modification Warning

High End Systems products are designed and manufactured to meet the requirements of United States and International safety regulations. Modifications to the product could affect safety and render the product non-compliant to relevant safety standards.

Mise En Garde Contre La Modification Du Produit

Les produits High End Systems sont conçus et fabriqués conformément aux exigences des règlements internationaux de sécurité. Toute modification du produit peut entraîner sa non conformité aux normes de sécurité en vigueur.

Produktmodifikationswarnung

Design und Herstellung von High End Systems entsprechen den Anforderungen der U.S. Amerikanischen und internationalen Sicherheitsvorschriften. Abänderungen dieses Produktes können dessen Sicherheit beeinträchtigen und unter Umständen gegen die diesbezüglichen Sicherheitsnormen verstoßen.

Avvertenza Sulla Modifica Del Prodotto

I prodotti di High End Systems sono stati progettati e fabbricati per soddisfare i requisiti delle normative di sicurezza statunitensi ed internazionali. Qualsiasi modifica al prodotto potrebbe pregiudicare la sicurezza e rendere il prodotto non conforme agli standard di sicurezza pertinenti.

Advertencia De Modificación Del Producto

Los productos de High End Systems están diseñados y fabricados para cumplir los requisitos de las reglamentaciones de seguridad de los Estados Unidos e internacionales. Las modificaciones al producto podrían afectar la seguridad y dejar al producto fuera de conformidad con las normas de seguridad relevantes.

Warranty Information

Limited Warranty

Unless otherwise stated, your product is covered by a one year parts and labor limited warranty. Dichroic filters and LithoPatterns® high resolution glass gobos are not guaranteed against breakage or scratches to coating. It is the owner's responsibility to furnish receipts or invoices for verification of purchase, date, and dealer or distributor. If purchase date cannot be provided, date of manufacture will be used to determine warranty period.

Returning an Item Under Warranty for Repair

It is necessary to obtain a Return Material Authorization (RMA) number from your dealer or point of purchase BEFORE any units are returned for repair. The manufacturer will make the final determination as to whether or not the unit is covered by warranty.

A fixture must be returned in its original packaging. Any other parts returned to High End Systems must be packaged in a suitable manner to ensure the protection of such product unit or parts, and such package shall be clearly and prominently marked to indicate that the package contains returned Product units or parts and with an RMA number. Accompany all returned Product units or parts with a written explanation of the alleged problem or malfunction. Ship returned Product units or parts to: 2105 Gracy Farms Lane, Austin, TX 78758 USA.

Note: Freight Damage Claims are invalid for fixtures shipped in non-factory boxes and packing materials.

Freight

All shipping will be paid by the purchaser. Items under warranty shall have return shipping paid by the manufacturer only in the Continental United States. Under no circumstances will freight collect shipments be accepted. Prepaid shipping does not include rush expediting such as air freight. Air freight can be sent customer collect in the Continental United States.

REPAIR OR REPLACEMENT AS PROVIDED FOR UNDER THIS WARRANTY IS THE EXCLUSIVE REMEDY OF THE CONSUMER. HIGH END SYSTEMS, INC. MAKES NO WARRANTIES, EXPRESS OR IMPLIED, WITH RESPECT TO ANY PRODUCT, AND HIGH END SPECIFICALLY DISCLAIMS ANY WARRANTY OF MERCHANTABILITY OR FITNESS FOR A PARTICULAR PURPOSE. HIGH END SHALL NOT BE LIABLE FOR ANY INDIRECT, INCIDENTAL OR CONSEQUENTIAL DAMAGE, INCLUDING LOST PROFITS, SUSTAINED OR INCURRED IN CONNECTION WITH ANY PRODUCT OR CAUSED BY PRODUCT DEFECTS OR THE PARTIAL OR TOTAL FAILURE OF ANY PRODUCT REGARDLESS OF THE FORM OF ACTION, WHETHER IN CONTRACT, TORT (INCLUDING NEGLIGENCE), STRICT LIABILITY OR OTHERWISE, AND WHETHER OR NOT SUCH DAMAGE WAS FORESEEN OR UNFORESEEN.

Warranty is void if the product is misused, damaged, modified in any way, or for unauthorized repairs or parts. This warranty gives you specific legal rights, and you may also have other rights which vary from state to state.

Important Safety Information

Instructions pertaining to continued protection against fire, electric shock, and injury to persons are found throughout this manual. Please read all instructions prior to assembling, mounting, and operating this equipment.

The following international caution and warning symbols appear in margins throughout this manual to highlight messages.



This symbol appears adjacent to Caution messages. Not heeding these messages could result in personal injury and/or damage to equipment.



This symbol appears adjacent to high voltage warning messages. Not heeding these messages could result in serious personal injury.



This symbol cautions against mounting the fixture on or near a flammable surface.



This symbol indicates that, while operating, equipment surfaces may reach very high temperatures. Allow the fixture to cool before handling.

Fixture Overview

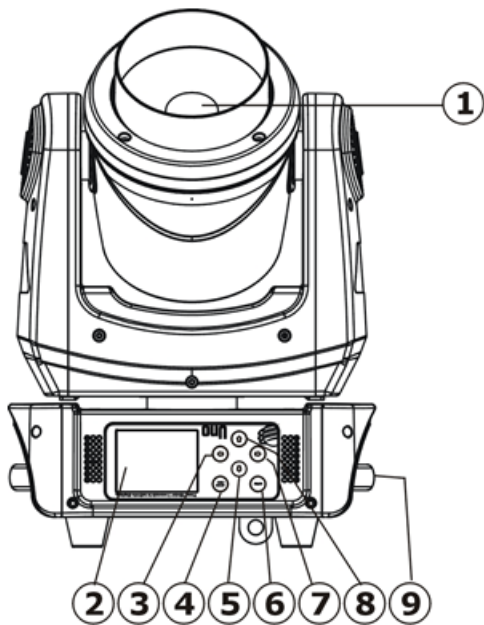

- 1: Lens
- 2: Display
- 3: Left-button
- 4: Mode/Esc-button
- 5: Down-button
- 6: ENTER-button
- 7: Right-button
- 8: Up-button
- 9: Handle
- 10: Fuse
- 11: Power out
- 12: Power in
- 13: 5 pin - DMX out
- 14: 5 pin - DMX in

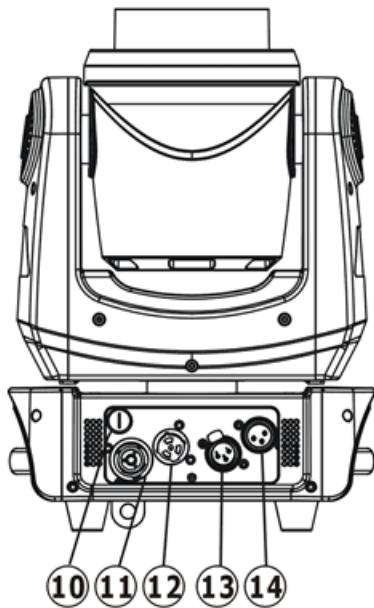

Features

- 60W high power LEDs
- Extremely Long Life:50,000 Hr and low power consumption.
- DMX channel mode: 15 channels.
- Pan/tilt movement: 16 bit resolution
 - For smooth and precise resolution.
 - Pan: 540° Tilt: 265°movement.
 - High speed of pan/tilt movement, speed of pan/tilt movement is adjustable.
 - Scan position memory, auto reposition after unexpected movement.
- Strobe effect with 18 flashes per second and pulse effect .
- General dimming and blackout for all four colors.
- Excellent color mixing and rainbow effect.
- Display: Can be changed 180° reverse to fit for different installation position.
- Dimmer intensity from 0%~100%.
- Control board with full color LCD graphic display and touch-keyboard.
- Rechargeable Back up Battery for Display.
- Software-upload by optional accessory via DMX line.

Safety Considerations



CAUTION: The information in this chapter is intended to assist qualified personnel *only*.



WARNING: Disconnect power before servicing. Replace fuses with the specified type and rating *only*.

This device has left the factory in perfect condition. In order to maintain this condition and to ensure a safe operation, it is absolutely necessary for the user to follow the safety instructions and warning notes written in this user manual.

Important:

Damages caused by the disregard of this user manual are not subject to warranty. The dealer will not accept liability for any resulting defects or problems.

- If the device has been exposed to temperature changes due to environmental changes, do not switch it on immediately. The condensation could cause damage to the device. Leave the device switched off until it has reached room temperature.
- This device falls under protection-class I. Therefore it is essential that the device be earthed.
- If protection screen, lens or ultraviolet screen in the fixture is apparently damaged or is damaged to exceed their own effective degree, such as cracked and gashed, it must be replaced.
- The electrical connection must carry out by a qualified person.
- Make sure that the available voltage is within stated range.
- Make sure the power cord is never crimped or damaged by a sharp edge. Replace cable immediately if damaged, this work must be done by an authorized dealer.
- Always disconnect from power, when the device is not in use or before cleaning it. Only handle the power cord by the plug. Never pull out the plug by tugging the power cord.
- Don't project the beam onto combustible substances, as this causes a safety hazard.
- Please be aware that damages caused by manual modifications will void warranty.
- During initial start-up some smoke or smell may arise. This is a normal process and does not necessarily mean that the device is defective, it should decrease gradually
- If the external flexible cable or cord of this luminaire is damaged, it shall be exclusively replaced by the manufacturer or his service agent or a similar qualified person in order to avoid a hazard. All screws for installing the devices or parts of the device have to be tightly connected and must not be corroded.
- There must not be any deformations on the housing, color lenses, fixations and installation spots (ceiling, suspension, trussing).
- Mechanically moved parts must not show any traces of wearing and must not rotate with unbalances.
- The electric power supply cables must not show any damage, material fatigue or sediments.
- Further instructions depending on the installation spot and usage have to be administered by a skilled installer and any safety problems have to be removed.

General Guidelines

- This device is a lighting effect for professional use on stages, theaters, or other professional installations, etc., the device was designed for indoor use only.
- This fixture is only allowed to be operated with the max alternating current which stated in the technical specifications printed on the fixture.
- Lighting effects are not designed for permanent operation. Consistent operation breaks may ensure that the device will serve you for a long time without defects.
- Do not shake the device .Avoid brute force when installing or operating the device.
- While choosing the installation-spot, please make sure that the device is not exposed to extreme heat, moisture or dust. Please don't project the beam onto combustible substances. The minimum distance between light-output from the projector and the illuminated surface must be more than 0.5 meter.
- If you use the quick lock cam in hanging up the fixture, please make sure the quick lock fasteners turned in the quick lock holes correctly.
- Operate the device only after having familiarized with its functions. Do not permit operation by persons not qualified for operating the device. Most damages are the result of unprofessional operation.
- Please use the original packaging if the device is to be transported.
- For safety reasons, please be aware that all modifications on the device are forbidden.
- If this device will be operated in any way different to the one described in this manual, the product may suffer damages and the guarantee becomes void. Furthermore, any other operation may lead to short-circuit, burns, electric shock, lamp explosion, crash, etc.
- In order to make the lights in good condition and extend the life time, we suggest a regular cleaning to the lights.

Installation Instructions

- The installation must always be secured with a secondary safety attachment, e.g. an appropriate safety cable.
- The installation of the effect has to be built and constructed in a way that it can hold 10 times the weight for 1 hour without any harming deformation.
- The applicable temperature for the lighting is between -10°C to 45°C. Do not use the lighting under or above the temperature.
- Never stand directly below the device when mounting, removing or servicing the fixture.
- The operator has to make sure the safety and technical installations are approved by an expert before taking using this fixture in the field for the first time.
- These installations must be inspected by a skilled person once a year.
- Overhead mounting requires extensive experience, including amongst others calculating working load limits, installation material being used, and periodic safety inspection of all installation material and the device. If you lack these qualifications, do not attempt the installation yourself. Improper installation can result in serious bodily injury.

Attachment Instructions

- Attach the Omega clamp on the bracket by tighten the M12 bolt on the bracket to the hole in the middle of the bracket.
- Insert the quick-lock fasteners of the bracket into the respective holes on the bottom of the fixture.
- Tighten the quick-lock fasteners fully clockwise.
- Install the second Omega clamp.
- Attach the safety-cable through the holes on the bottom of the base. Attach to the trussing system or other safe fixation point.
- Be sure the safety is fully looped, the quick-link is attached and fully tighten
- Inspect for complete attachment before lifting over-head

Installation via the Omega holders

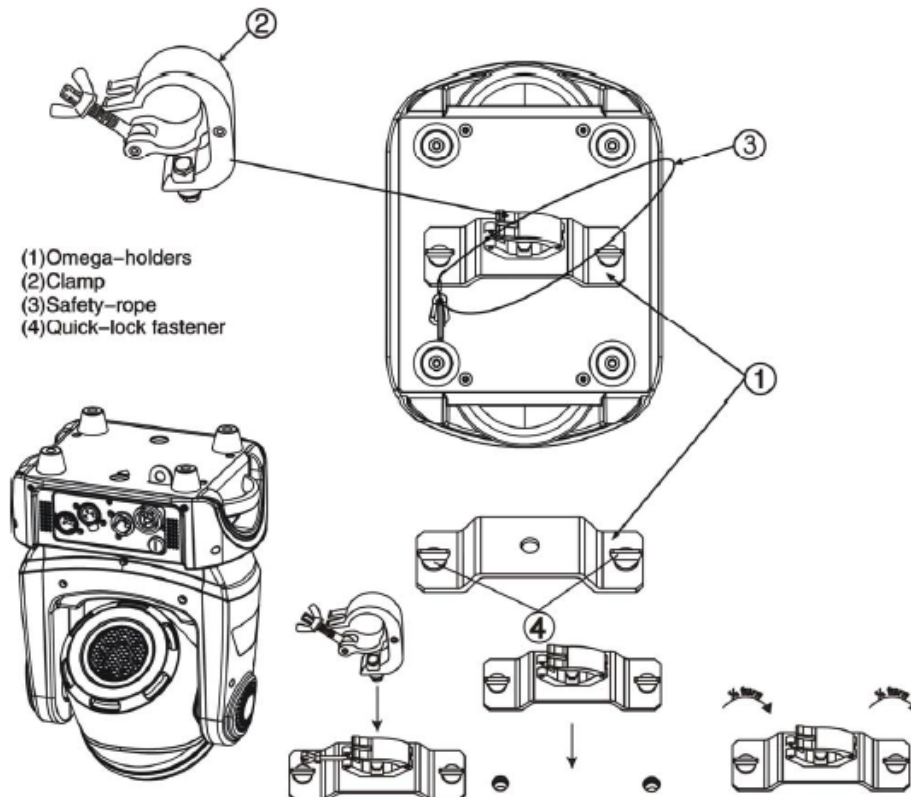

Technical Specifications

- Power supply: AC 100-240V~, 50/60Hz
- Power consumption: 110W
- Packing dimensions: 31.5x24.5x46cm
- Net weight: 5.5 KGS
- Gross weight: 10.5 KGS

Dimensional Drawings:

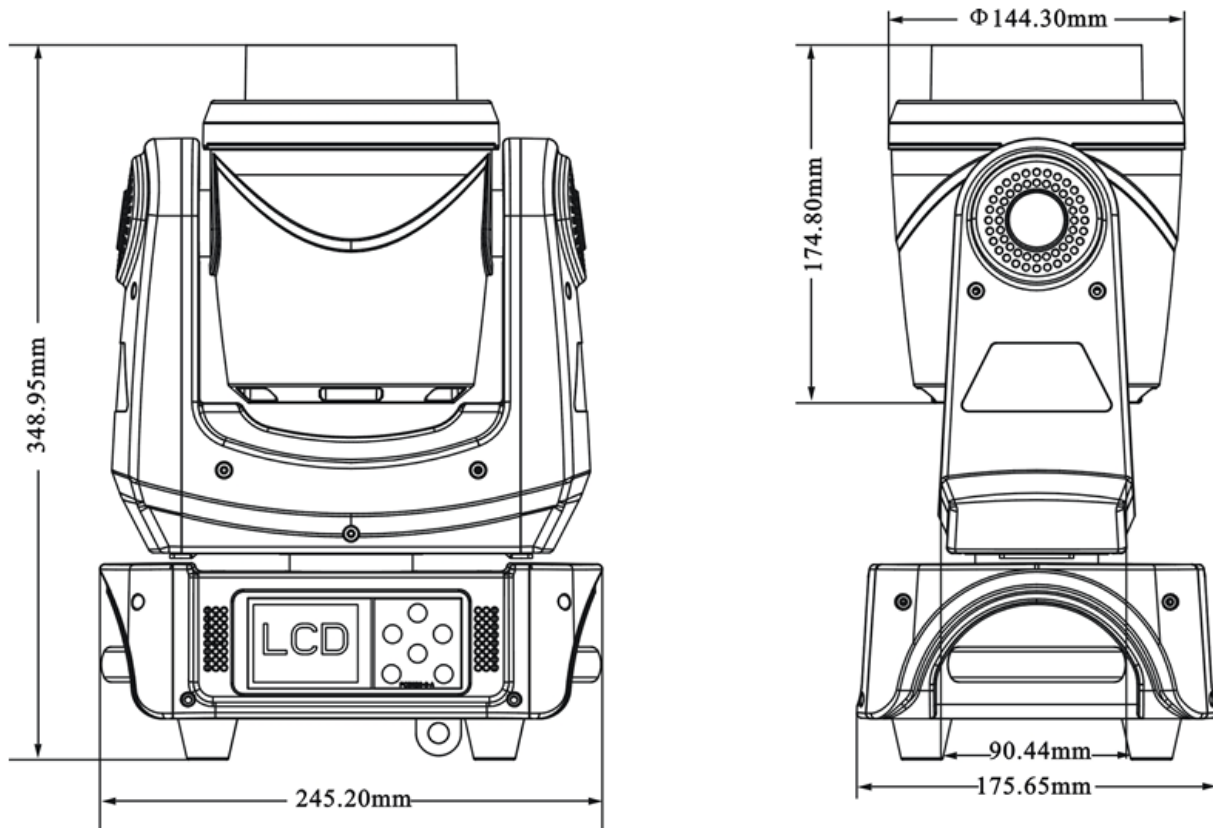

Mounting

Be sure this fixture is kept at least 0.5m away from any flammable materials (decoration etc.). Always use and install the supplied safety cable as a safety measure to prevent accidental damage and/or injury in the event the clamp fails.

Overhead mounting requires extensive experience, including amongst others calculating working load limits, a fine knowledge of the installation material being used, and periodic safety inspection of all installation material and the fixture. If you lack these qualifications, do not attempt the installation yourself. Improper installation can result in bodily injury.

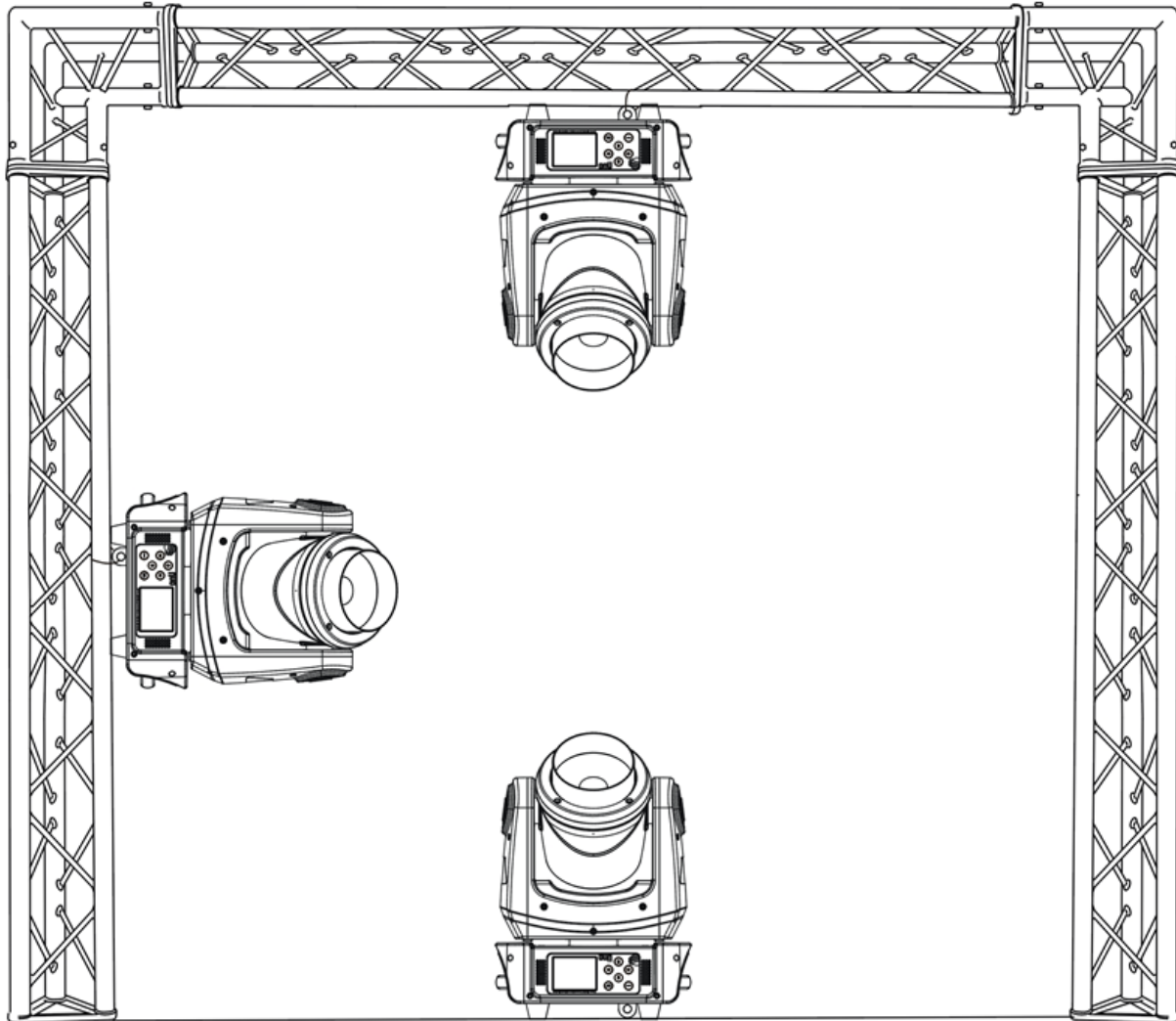

DMX Control Connection

Connect the provided XLR cable to the female 5-pin XLR output of your controller and the other side to the male 5-pin XLR input of the moving head. You can chain multiple moving heads together through serial linking. The cable needed should be two core, screened cable with XLR input and output connectors. Please refer to the diagram below:

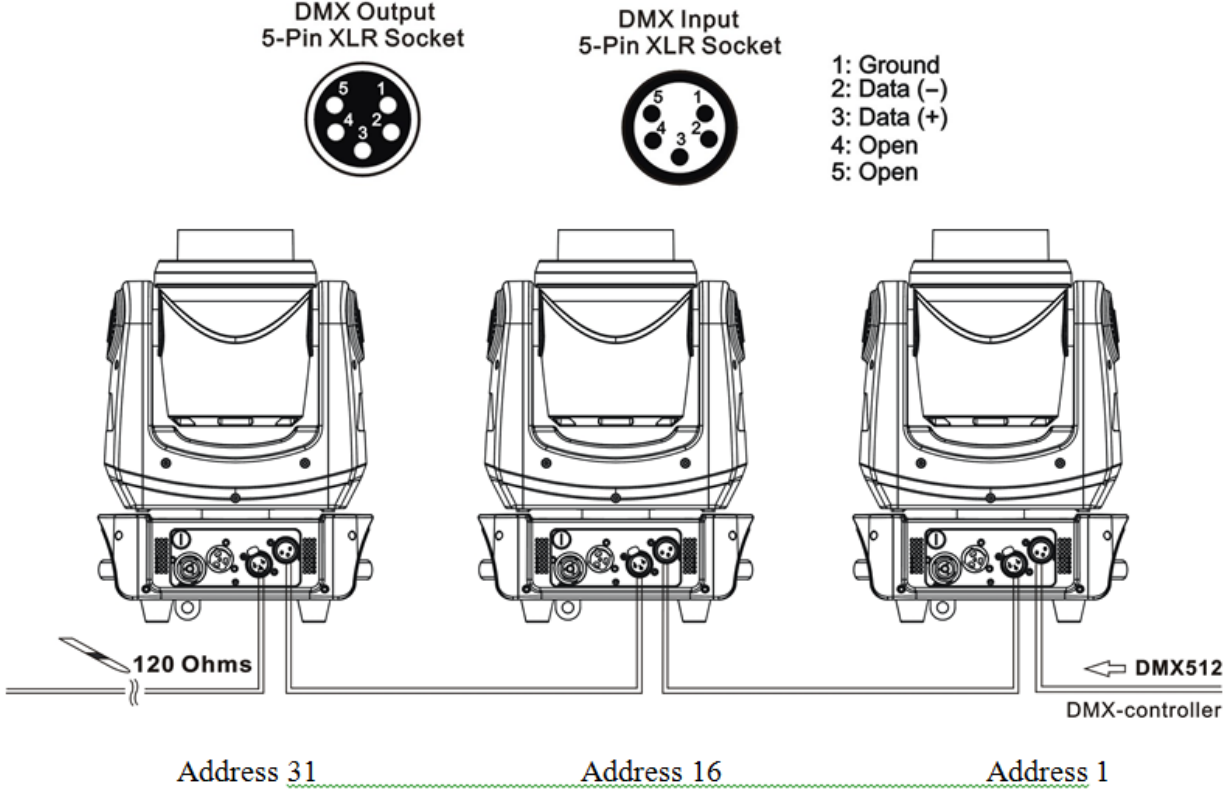

DMX Start Address

All fixtures should be given a DMX starting address when using a DMX signal, so that the correct fixture responds to the correct control signals. This digital starting address is the channel number from which the fixture starts to “listen” to the digital control information sent out from the DMX controller. The allocation of this starting address is achieved by setting the correct number on the display located on the base of the device.

You can set the same starting address for all fixtures or a group of fixtures, or make different address for each fixture individually.

If you set the same address, all the units will start to “listen” to the same control signal from the same channel number. In other words, changing the settings of one channel will affect all the fixtures simultaneously.

If you set a different address, each unit will start to “listen” to the channel number you have set, based on the quantity of control channels of the unit. That means changing the settings of one channel will affect only the selected fixture.

In the case of this LED moving head, which is a 15 channel fixture, you should set the starting address of the first unit to 1, the second unit to 16(15 + 1), the third unit to 31 (15+16), and so on.

DMX Connection with DMX terminator

For installations where the DMX cable has to run a long distance or is in an electrically noisy environment, such as in a discotheque, it is recommended to use a DMX terminator. This helps in preventing corruption of the digital control signal by electrical noise. The DMX terminator is simply an XLR plug with a 120 Ω resistor connected between pins 2 and 3, which is then plugged into the output XLR socket of the last fixture in the chain. Please see illustrations below:

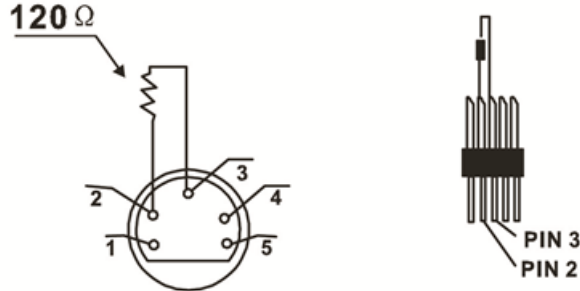

Control Board

Address	A001~AXXX			DMX address setting
Info	Time Info.	Current Time Ttl Life Hrs Last Run Hrs LED Hours Timer PIN Clr Last Run LED Time PIN Clen LED Time	XXXX(Hours) XXXX(Hours) XXXX(Hours) XXXX(Hours) Password=XXX ON/OFF Password=XXX ON/OFF	Power on running time Fixture running time Fixture Last times clear Lamp running time Timer Password 038 Clear Fixture Last time Lamp Password ="038" Clear lamp time
	Value Disp.	NONE ALL PAN.....		DMX mode choose DMX value display
	Head Temp.	XXX°C/°F		Temperature in the head
	Software Ver	Ver1.0.....		Software version
Set	Status	No DMX Mode Pan Reverse Tilt Reverse Pan Degree Encoders. Hibernation	Close Hold / Auto ON/OFF ON/OFF 540 / 630 ON/OFF OFF, 01M~99M, 15M	Add. via DMX Pan Reverse movement Tilt Reverse movement Pan Degree Select Movement Mode Select Stand by Mode
	Service PIN	Service PIN RDM PID	Password=XXX xxxxxx	Service Password="050" RDM PID Code
	Disp. Setting	Shutoff Time Flip Display Key Lock	02~60m 05m ON/OFF ON/OFF	Display shutoff time Reverse 180 degree Key Lock
	Temp. C/F	Fahrenheit Celsius		Temperature switch between °C/°F
	ResetDefault	ON/OFF		Restore factory set.
Test	Home	All Pan&Tilt		Reset all motors Reset Pan/Tilt
	Test Channel	PAN		Test function
	Manual Ctrl.	PAN =XXX :		Fine adjustment of the lamp
	Calibration	-Password- Pan =XXX :		Password "050" Calibrate and adjust the effects to standard/right position
Preset	PlayBack	DMX Control Set To Slave Auto Program	Slave1, Slave2, Slave3 Master / Alone	User's mode to change channel numbers
	Select Prog.	Prog. Part 1 = Program 1 ~ 10 Prog. Part 2 = Program 1 ~ 10 Prog. Part 3 = Program 1 ~ 10	Program 1 Program 2 Program 3	Select programs to be run
	Edit Prog.	Program 1 : Program 10	Program Test Step 01=SCxxx Step 64=SCxxx	Testing program Program in loop Save and exit
	Edit Scenes	Edit Scene 001 ~ Edit Scene 250	Pan, Tilt, --Fade Time-- --Secne Time-- Input By Outside	Save and automatically return manual scenes edit
	Scenes Input	XX~XX		Automat. scenes rec

Control Board Functions

Address

With this function, you can adjust the desired DMX-address via the Control Board.

1. Access the main menu.
2. Tap the <Up/Down> button until "Set DMX Address" is displayed.
3. Press ENTER, the display will show "Set DMX Address".
4. Tap the <Up/Down> button, the display will show "A001~AXXX"
5. Press ENTER to confirm or press <MODE/ESC> to return to the main menu.

Info.

Time Info

Current Time

With this function, you can display the temporary running time of the device from the last power on. The display shows "XXXX", "XXXX" stands for the number of hours. The counter is reset after turning the device off.

1. Tap <MODE/ESC> button, access the main menu Tap the <Up/Down> button until " Info" is displayed. Press ENTER, the display will show "Info". Tap the <Up/Down>button until the display will show "Time Info.". Press ENTER, the display will show "Time Info.". Press <Up/Down> the display will show "Current Time".
2. Press <Up/Down> the display will show "Current Time".
3. Press < ENTER> the display will show "Current Time".
4. The display will show "XXXX" (Hours) ;
5. Press <ENTER> to confirm or press <MODE/ESC> to return to the main menu.

Ttl Life Hrs

With this function, you can display the running time of the device. The display shows "XXXX", "XXXX" stands for the number of hours.

1. Tap <MODE/ESC>button, access the main menu Tap the <Up/Down>button until " Info" is displayed. Press ENTER, the display will show "Info". Tap the <Up/Down>button until the display will show "Time Info.". Press ENTER, the display will show "Time Info.". Press <Up/Down> the display will show "Ttl Life Hrs".
2. Press <Up/Down> the display will show "Ttl Life Hrs".
3. Press<ENTER> the display will show " Ttl Life Hrs".
4. The display will show "XXXX" (Hours) ;
5. Press <ENTER> to confirm or press <MODE/ESC> to return to the main menu.

Last Run Hrs

With this function, you can display last the running time of the lamp. The display shows "XXXX", "XXXX" stands for the number of hours

1. Tap <MODE/ESC>button, access the main menu Tap the <Up/Down>button until " Info" is displayed. Press ENTER, the display will show "Info". Tap the <Up/Down>button until the display will show "Time Info.". Press ENTER, the display will show "Time Info.". Press <Up/Down> the display will show "Last Run Hrs".
2. Press <Up/Down> the display will show "Last Run Hrs".
3. Press<ENTER> the display will show " Last Run Hrs".
4. The display will show "XXXX" (Hours) ;
5. Press <ENTER> to confirm or press <MODE/ESC> to return to the main menu.

LED Hour

With this function, you can display the running time of the lamp. The display shows "XXXX", "XXXX" stands for the number of hours.

1. Tap <MODE/ESC>button, access the main menu Tap the <Up/Down>button until " Info" is displayed. Press< ENTER>, the display will show "Info". Tap the <Up/Down>button until the display will show "Time Info.". Press< ENTER>, the display will show "Time Info.". Press <Up/Down> the display will show "LED Hours".
2. Press <Up/Down> the display will show "LED Hours".
3. Press<ENTER> the display will show "LED Hours".
4. The display will show "XXXX" (Hours) ;
5. Press <ENTER> to confirm or press <MODE/ESC> to return to the main menu.

Timer PIN

With this function, you can display the timer password. The time password is 038.

1. Tap <MODE/ESC>button, access the main menu Tap the <Up/Down>button until " Info" is displayed. Press ENTER, the display will show "Info". Tap the <Up/Down>button until the display will show "Time Info.". Press ENTER, the display will show "Time Info.". Press <Up/Down> the display will show "Timer PIN".
2. Press <Up/Down> the display will show "Timer PIN".

3. Press <ENTER> the display will show "Timer PIN", the time password is 038.
4. Press <ENTER> to confirm or press <MODE/ESC> to return to the main menu.

Clr Last Run

With this function, you can clear last run time of the fixture. The display shows "ON" or "OFF", Press "Enter" to confirm.

1. Tap <MODE/ESC>button, access the main menu Tap the <Up/Down>button until "Info" is displayed. Press< ENTER>, the display will show "Info". Tap the <Up/Down>button until the display will show "Time Info.". Press ENTER, the display will show "Time Info."
2. Press <Up/Down>;, the display will show "Clr Last Run".
3. At " L-Timer Password" menu input right password, Press<ENTER>;, the display will show "Clr Last Run".
4. The display show "OFF", Press <Up/Down> the display will show "ON".
5. Press <ENTER> to confirm or press <MODE/ESC> to return to the main menu.

LED Time PIN

With this function, you can display the timer password. The time password is 038.

1. Tap <MODE/ESC>button, access the main menu Tap the <Up/Down>button until "Info" is displayed. Press ENTER, the display will show "Info". Tap the <Up/Down>button until the display will show "Time Info.". Press ENTER, the display will show "Time Info."
2. Press <Up/Down> the display will show "LED Time PIN".
3. Press<ENTER> the display will show "LED Time PIN", the time password is 038.
4. Press <ENTER> to confirm or press <MODE/ESC> to return to the main menu.

Clen LED Time

With this function you can clear the running time of the lamp. Please clear the lamp time every time you replace the lamp.

1. Tap <MODE/ESC>button, access the main menu Tap the <Up/Down>button until "Info" is displayed. Press ENTER, the display will show "Info". Tap the <Up/Down>button until the display will show "Time Info.". Press ENTER, the display will show "Time Info."
2. Press <Up/Down> the display will show "Clen LED Time".
3. At "Timer Password "menu input a correct password, press <ENTER> the display will show "Clen LED Time",
4. The display will show "OFF"or"ON".
5. Press <ENTER> to confirm or press <MODE/ESC> to return to the main menu.

Value Disp.

NONE

With this function, you can choose the DMX channel.

1. Tap <MODE/ESC>button, access the main menu Tap the <Up/Down>button until "Info" is displayed. Press ENTER, the display will show "Info". Tap the <Up/Down>button until the display will show "Value Disp". Press ENTER, the display will show "Value Disp".
2. Press <Up/Down> the display will show "NONE".
3. Press<ENTER> the display will show "NONE".
4. Press <ENTER> to confirm or press <MODE/ESC> to return to the main menu.

DMX Value

With this function you can display the DMX 512 value of each channel. The display automatically shows the channel with a value changing.

1. Tap <MODE/ESC>button, access the main menu Tap the <Up/Down>button until "Info" is displayed. Press ENTER, the display will show "Info". Tap the <Up/Down>button until the display will show "Value Disp". Press ENTER, the display will show "Value Disp".
2. Tap the <Up/Down>button until "ALL", "PAN" is displayed.
3. Tap the <Up/Down>button, choose each channel.
4. Press ENTER to confirm or press <MODE/ESC> to return to the main menu.

Head Temperature

With this function you can display the temperature on the display board of the base (near CMY-filter) in Celsius.

1. Tap <MODE/ESC>button, access the main menu Tap the <Up/Down>button until "Info" is displayed. Press ENTER, the display will show "Info". Tap the <Up/Down>button until " Head Temp." is displayed. Press ENTER, the display will show "Head Temp."
2. The display show "XXX °C/ °F".
3. Press <ENTER> to confirm or press <MODE/ESC> to return to the main menu.

Software Version

With this function, you can display the software version of the device.

1. Tap <MODE/ESC>button, access the main menu Tap the <Up/Down>button until "Info" is displayed. Press ENTER, the display will show "Info".
2. Press <Up/Down> the display will show "Software Ver".
3. Press<ENTER> the display will show "Software Ver".
4. The display show "Ver x.x.x".
5. Press <ENTER> to confirm or press <MODE/ESC> to return to the main menu.

SET

Status

No DMX Status

With this function, when the drive is not DMX signal, it runs automatism, close, hold and music, the default is hold.

1. Tap <MODE/ESC>button, access the main menu Tap the <Up/Down>button until "SET" is displayed. Press ENTER, the display will show "SET". Tap the <Up/Down>button until the display will show "Status". Press ENTER, the display will show "Status".
2. Press <Up/Down> the display will show "No DMX Status".
3. Press<ENTER> the display will show "No DMX Status".
4. The display show "Hold", Press <Up/Down> the display will show "Close", "Auto",.
5. Press <ENTER> to confirm or press <MODE/ESC> to return to the main menu.

Pan Reverse

With this function you can reverse the Pan-movement.

1. Tap <MODE/ESC>button, access the main menu Tap the <Up/Down>button until "SET" is displayed. Press ENTER, the display will show "SET". Tap the <Up/Down>button until the display will show "Status". Press ENTER, the display will show "Status".
2. Press <Up/Down> the display will show "Pan Reverse".
3. Press<ENTER> the display will show "Pan Reverse".
4. The display show "OFF", Press <Up/Down>,the display will show "ON".
5. Press <ENTER> to confirm or press <MODE/ESC> to return to the main menu.

Tilt Reverse

With this function you can reverse the Tilt-movement.

1. Tap <MODE/ESC>button, access the main menu Tap the <Up/Down>button until "SET" is displayed. Press ENTER, the display will show "SET". Tap the <Up/Down>button until the display will show "Status". Press ENTER, the display will show "Status".
2. Press <Up/Down> the display will show "Tilt Reverse".
3. Press<ENTER>the display will show "Tilt Reverse".
4. The display show "OFF", Press <Up/Down> the display will show "ON".
5. Press <ENTER> to confirm or press <MODE/ESC> to return to the main menu.

Encoders

With this function, you can feedback switch of pan movement or tilt movement.

1. Tap <MODE/ESC>button, access the main menu Tap the <Up/Down>button until "SET" is displayed. Press ENTER, the display will show "SET". Tap the <Up/Down>button until the display will show "Status". Press ENTER, the display will show "Status".
2. Press <Up/Down> the display will show "Encoders".
3. Press<ENTER> the display will show "Encoders".
4. The display show "ON", Press <Up/Down> the display will show "OFF".
5. Press <ENTER> to confirm or press <MODE/ESC> to return to the main menu.

Hibernation —Standby mode

The lamp and step motors will be power off if the fixture stay without DMX signal for 15 mins (Factory default).And the fixture will be reset before working once it receive DMX signal again.

1. Tap <MODE/ESC>button, access the main menu Tap the <Up/Down>button until "SET" is displayed. Press ENTER, the display will show "SET". Tap the <Up/Down>button until the display will show "Status". Press ENTER, the display will show "Status".
2. Press <Up/Down> the display will show "Hibernation".
3. Press<ENTER> the display will show "Hibernation".
4. The display show "15M",Press <Up/Down> the display will show "01M", "02M", "99M" or "OFF".
5. Press <ENTER> to confirm or press <MODE/ESC> to return to the main menu.

Service PIN

Password—The Password for this function is "50".

RDM PID—With this function you can call up various submenus via RDM.

This device is RDM ready. RDM stands for "remote device management" and makes remote control of devices connected to the DMX-bus. ANSI E1.20-2006 by ESTA specifies the RDM standard as an extension of the DMX512 protocol.

Manual settings like adjusting the DMX starting address are no longer needed. This is especially useful when the device is installed in a remote area.

RDM ready and conventional DMX devices can be operated in one DMX line. The RDM protocol sends own packages in the DMX512 data feed and does not influence conventional devices.

If DMX splitters are used and RDM control is to be used, these splitters must support RDM.

The number and type of RDM parameters depend on the RDM controller being used.

Display Settings

Shut off time

With this function you can shut off the color LCD display after 2 to 59 minutes. Turn the encoder in order to select the desired shut off time. The default is 5 minute.

1. Tap <MODE/ESC>button, access the main menu Tap the <Up/Down>button until "Set" is displayed. Press ENTER, the display will show "Set". Tap the <Up/Down>button until the display will show "Disp.Setting". Press ENTER, the display will show "Disp.Setting".
2. Press <Up/Down> the display will show " Shutoff Time".
3. Press<ENTER> the display will show " Shutoff Time".

Filp Display

With this function you can the entire display to be flipped by 180° to allow for better view when the fixture is hung from truss or a ceiling. This function is disabled as default.

1. Tap <MODE/ESC>button, access the main menu Tap the <Up/Down>button until "Set" is displayed. Press ENTER, the display will show "Set". Tap the <Up/Down>button until the display will show "Disp.Setting". Press ENTER, the display will show "Disp.Setting".
2. Press <Up/Down> the display will show "Filp Display".
3. Press<ENTER> the display will show "Filp Display".
4. The display show "OFF", Press <Up/Down> the display will show "ON".
5. Press <ENTER>; to confirm or press <MODE/ESC>; to return to the main menu.

Key Lock

With this function you can activate the automatic keylock status. If this function is activated, the keys will be locked automatically after exiting the edit mode for 15 seconds. keeping press the [MENU] key for 3seconds if you do not need this function.

1. Tap <MODE/ESC>button, access the main menu Tap the <Up/Down>button until "Set" is displayed. Press ENTER, the display will show "Set". Tap the <Up/Down>button until the display will show "Disp.Setting". Press ENTER, the display will show "Disp.Setting".
2. Press <Up/Down> the display will show "Key Lock".
3. Press< ENTER> the display will show "Key Lock".
4. The display show "OFF", Press <Up/Down>;, the display will show "ON".
5. Press <ENTER>; to confirm or press &<MODE/ESC>; to return to the main menu.

Temperature C/F

With this function, Display the temperature for Celsius or Fahrenheit.

1. Tap <MODE/ESC>button, access the main menu Tap the <Up/Down>button until " Set" is displayed. Press ENTER, the display will show "Set".
2. Press <Up/Down>the display will show "Temp. C/F".
3. Press<ENTER> the display will show " Temp. C/F".
4. The display show "Celsius", Press <Up/Down> the display will show "Fahrenheit".
5. Press <ENTER>; to confirm or press <MODE/ESC>; to return to the main menu.

Reset Default

With this function, you can select restore factory set for ON or OFF, the default is OFF.

1. Tap <MODE/ESC>button, access the main menu Tap the <Up/Down>button until "Personality" is displayed. Press ENTER, the display will show "Personality".
2. Press <Up/Down>the display will show "Reset Default".
3. Press<ENTER> the display will show "Reset Default".
4. The display show "OFF", Press <Up/Down> the display will show "ON".
5. Press <ENTER>; to confirm or press <MODE/ESC>; to return to the main menu.

Test

Home

With this function you can reset the device via the Control Board. You can select the different reset functions by turning the encoder.

1. Tap <MODE/ESC>button, access the main menu Tap the <Up/Down>button until " Test" is displayed. Press ENTER, the display will show "Test".
2. The display show "Reset All", Press <Up/Down> the display will show "Reset Pan & Tilt".
3. Press <ENTER>; to confirm or press <MODE/ESC>; to return to the main menu.

Test channel

With this function you can test each channel on its (correct) function.

1. Tap <MODE/ESC>button, access the main menu Tap the <Up/Down>button until " Test" is displayed. Press ENTER, the display will show "Test".
2. Press <Up/Down> the display will show "Test Channel".
3. Press<ENTER> the display will show "Test Channel".
4. The display show "Pan Moving "first channel, Press <Up/Down> can choose other channel.
5. Press <ENTER>; to confirm or press <MODE/ESC>; to return to the main menu

Manual control

With this function, you can adjust the lamp more easily. All effects will be canceled, the shutter opens and the dimmer intensity will be set to 100 %. With the individual functions, you can focus the light on a flat surface (wall) and perform the fine lamp adjustment.

1. Tap <MODE/ESC>button, access the main menu Tap the <Up/Down>button until " Test" is displayed. Press ENTER, the display will show "Test".
2. Press <Up/Down> the display will show "Manual Ctrl.".
3. Press<ENTER> the display will show "Manual Ctrl.".
4. The display show "PAN=XXX".
5. Press <ENTER>; to confirm or press <MODE/ESC>; to return to the main menu.

Calibration

With this function, you can calibrate and adjust the effect wheels to their correct positions. The password of calibrate values is 050.

1. Tap <MODE/ESC>button, access the main menu Tap the <Up/Down>button until " Test" is displayed. Press ENTER, the display will show "Test".
2. Press <Up/Down> the display will show "Calibration".
3. Press<ENTER> the display will show "Calibration".
4. The display show "Password=XXXX".
5. Press<ENTER>; to confirm or press <MODE/ESC>; to return to the main menu.

Preset Programming and Playback

Preset

Play Back

DMX Control

1. Tap <MODE/ESC>button, access the main menu Tap the <Up/Down>button until "Preset" is displayed. Press ENTER, the display will show "Preset". Tap the <Up/Down>button until the display will show "PlayBack". Press ENTER, the display will show "PlayBack".
2. Tap the <Up/Down>button until "DMX Control" is displayed.
3. Press ENTER, the display will show "DMX Control".
4. Tap the <Up/Down>button, choose DMX modes.
5. Press ENTER to confirm or press <MODE/ESC> to return to the main menu.

Set To Slave

With this function, you can define the device as slave.

1. Tap <MODE/ESC>button, access the main menu Tap the <Up/Down>button until "Preset" is displayed. Press ENTER, the display will show "Preset". Tap the <Up/Down>button until the display will show "PlayBack". Press ENTER, the display will show "PlayBack".
2. Tap the <Up/Down>button until "Set To Slav" is displayed
3. Press ENTER, the display will show "Set To Slav".
4. Tap the <Up/Down>button, the display will show "Slave1", "Slave2", "Slave3".
5. Press ENTER to confirm or press <MODE/ESC> to return to the main menu.

Auto Program

With this function, you can run the internal program. You can select the desired program under "Select prog."

You can set the number of steps under "Edit prog.". You can edit the individual scenes under "Edit scenes".

With this function, you can run the individual scenes either automatically, i.e. with the adjusted Step-Time.

1. Tap <MODE/ESC>button, access the main menu Tap the <Up/Down>button until "Preset" is displayed. Press ENTER, the display will show "Preset". Tap the <Up/Down>button until the display will show "PlayBack". Press ENTER, the display will show "PlayBack".
2. Tap the <Up/Down>button until "Auto Program" is displayed.
3. Press ENTER, the display will show "Auto Program"
4. Tap the <Up/Down> button, the display will show "Master1", " Alone".
5. Press ENTER to confirm or press <MODE/ESC> to return to the main menu.

Select programs

With this function, you can select the program for the Program Run.

Edit program

With this function, you can edit the internal programs.

Edit scenes

With this function, you can edit the scenes of the internal programs.

Scenes Input

The moving head features an integrated DMX-recorder by which you can transmit the programmed scenes from your DMX-controller to the moving head. Adjust the desired scene numbers via the encoder (from – to). When you call up the scenes at your controller, they will automatically be transmitted to the moving head.

Excursion:

A Master unit can send up to 3 different data groups to the Slave units, i.e. a Master unit can start 3 different Slave units, which run 3 different programs. The Master unit sends the 3 program parts in a continuous loop.

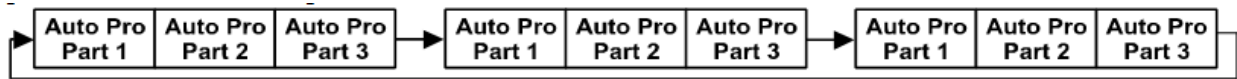

The Slave unit receives data from the Master unit according to the group which the Slave unit was assigned to. If e.g. a Slave unit is set to "Slave 1" in the menu "Set to Slave", the Master unit sends "Auto Program Part 1" to the Slave unit. If set to "Slave 2", the Slave unit receives "Auto Program Part 2".

To start a Auto Program please proceed as follows:

1. Slave-Setting

- Select "Function Mode" by turning the encoder.
- Press the Enter button to confirm.
- Select "Set to slave" by turning the encoder.
- Press the Enter button to confirm
- Turn the encoder to select "Slave 1", "Slave 2" or "Slave 3"
- Press the Enter button to confirm. • Press the MODE/ESC button in order to return to the main menu.

2. Automatic Program Run

- Select "Function Mode" by turning the encoder.
- Press the Enter button to confirm
- Select "Auto Program" by turning the encoder.
- Press the Enter button to confirm.
- Turn the encoder to select "Master" or "Alone". The selection "Alone" means Stand Alone-mode and "Master" that the device is defined as master.
- Press the Enter button to confirm. • Press the MODE/ESC button in order to return to the main menu.

3. Program selection for Auto Pro Part

- Select "Edit program" by turning the encoder.
- Press the Enter button to confirm
- Select "Select programs" by turning the encoder.
- Press the Enter button to confirm.
- Turn the encoder to select "Auto Pro Part 1", "Auto Pro Part 2" or "Auto Pro Part 3", and thus select which Slave program is to be sent. Selection "Part 1" means, that the Slave unit runs the same program as the master units.
- Press the Enter button to confirm.
- Press the MODE/ESC button in order to return to the main menu.

4. Program selection for Edit Program

- Select "Edit program" by turning the encoder.
- Press the Enter button to confirm.
- Select "Edit program" by turning the encoder.
- Press the Enter button to confirm.
- Turn the encoder to select the desired program. With this function you can edit specific scenes into a specific program.
- Press the Enter button to confirm.
- Press the MODE/ESC button in order to return to the main menu.

5. Automatic Scene Recording

- Select "Edit program" by turning the encoder.
- Press the Enter button to confirm.
- Select "Edit scenes" by turning the encoder.
- Turn the encoder to select the desired scene numbers. You can program a maximum number of 250
- Press the Enter button to confirm.
- Press the MODE/ESC button in order to return to the main menu.

Example:

Program 2 includes scenes: 10, 11, 12, 13

Program 4 includes scenes: 8, 9, 10

Program 6 includes scenes: 12, 13, 14, 15

Auto Pro Part 1 is Program 2;

Auto Pro Part 2 is Program 3;

Auto Pro Part 3 is Program 6

The 3 Slave groups run the Auto Program in certain time segments, as shown in the following picture:

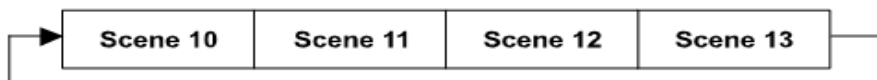

Part 2:

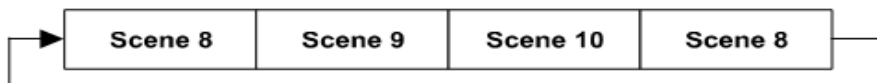

Part 3:

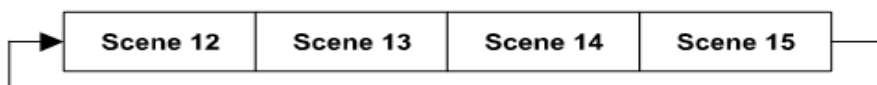

DMX Protocol

Channel	Marketing	Description	Decimal	Decimal	Percent	Percent	Hex	Hex	Controller Defaults
	Construct		Low	High	Low	High	Low	High	
1	Pan	Pan Coarse	0	255	0%	100%	00h	FFh	128
2	Pan	Pan Fine	0	255	0%	100%	00h	FFh	0
3	Tilt	Tilt Coarse	0	255	0%	100%	00h	FFh	128
4	Tilt	Tilt Fine	0	255	0%	100%	00h	FFh	0
		RGB	0	15	0%	6%	00h	0Fh	100
		RBG	16	30	6%	12%	10h	1Eh	
		BRG	31	45	12%	18%	1Fh	2Dh	
		BGR	46	60	18%	24%	2Eh	3Ch	
5	Mix Color	GRB	61	75	24%	29%	3Dh	4Bh	
	Function	GBR	76	90	30%	35%	4Ch	5Ah	
		CMY	91	105	36%	41%	5Bh	69h	
		Cycle	106	120	42%	47%	6Ah	78h	
		Random	121	135	47%	53%	79h	87h	
		Reserved	136	255	53%	100%	88h	FFh	
		RGB Control							0
		Red Off	0		0%		00h		
		Red Full Saturation	255		100%		FFh		
		RBG Control							
		Red Off	0		0%		00h		
		Red Full Saturation	255		100%		FFh		
		BRG Control							
		Blue Off	0		0%		00h		
		Blue Full Saturation	255		100%		FFh		
		BGR Control							
		Blue Off	0		0%		00h		
6	LED Red	Blue Full Saturation	255		100%		FFh		
		GRB Control							
		Green Off	0		0%		00h		
		Green Full Saturation	255		100%		FFh		
		GBR Control							
		Green Off	0		0%		00h		
		Green Full Saturation	255		100%		FFh		
		CMY Control							
		Red Full Saturation	0		0%		00h		
		Red Off	255		100%		FFh		
		Cycle & Random Modes. Scan Speed controlled by Red Channel							
		Slow Rate	0		0%		00h		
		Fast Rate	255		100%		FFh		
		RGB Control							0

		Green Off	0		0%	00h	
		Green Full Saturation	255		100%	FFh	
		RBG Control					
		Blue Off	0		0%	00h	
		Blue Full Saturation	255		100%	FFh	
		BRG Control					
		Red Off	0		0%	00h	
		Red Full Saturation	255		100%	FFh	
		BGR Control					
		Green Off	0		0%	00h	
7	LED Green	Green Full Saturation	255		100%	FFh	
		GRB Control					
		Red Off	0		0%	00h	
		Red Full Saturation	255		100%	FFh	
		GBR Control					
		Blue Off	0		0%	00h	
		Blue Full Saturation	255		100%	FFh	
		CMY Control					
		Green Full Saturation	0		0%	00h	
		Green Off	255		100%	FFh	
		RGB Control					
		Blue Off	0		0%	00h	
		Blue Full Saturation	255		100%	FFh	
		RBG Control					
		Green Off	0		0%	00h	
		Green Full Saturation	255		100%	FFh	
		BRG Control					
		Green Off	0		0%	00h	
		Green Full Saturation	255		100%	FFh	
		BGR Control					
		Red Off	0		0%	00h	
8	LED Blue	Red Full Saturation	255		100%	FFh	
		GRB Control					
		Blue Off	0		0%	00h	
		Blue Full Saturation	255		100%	FFh	
		GBR Control					
		Red Off	0		0%	00h	
		Red Full Saturation	255		100%	FFh	
		CMY Control					
		Blue Full Saturation	0		0%	00h	
		Blue Off	255		100%	FFh	

0

		RGB Control							
		White Off	0		0%		00h		
		White Full	255		100%		FFh		
		RBG Control							
		White Off	0		0%		00h		
		White Full	255		100%		FFh		
		BRG Control							
		White Off	0		0%		00h		
		White Full	255		100%		FFh		
		BGR Control							
		White Off	0		0%		00h		0
9	LED White	White Full	255		100%		FFh		
		GRB Control							
		White Off	0		0%		00h		
		White Full	255		100%		FFh		
		GBR Control							
		White Off	0		0%		00h		
		White Full	255		100%		FFh		
		CMY Control							
		White Off	0		0%		00h		
		White Full	255		100%		FFh		
	Shutter/	Normal Strobe Functions	0	31	0%	12%	00h	1Fh	
10	LED	Random Strobe	32	63	13%	25%	20h	3Fh	0
	Functions	Synchronous Random Strobe	64	95	25%	37%	40h	5Fh	
		Normal/Random/Sync shutter functions.							
		Close	0	23	0%	9%	00h	17h	
		Strobe Rate (slow to fast)	24	229	9%	90%	18h	E5h	
11	Shutter	Open	230	255	90%	100%	E6h	FFh	255
	Dim Coarse	Close	0		0%		00h		0
		Open	255		100%		FFh		
12									
13	Dim Fine		0		0%		00h		0
			255		100%		FFh		
		Disable	0	3	0%	1%	00h	03h	
		Longest (252.7 seconds)	4		2%		04h		
14	Speed	Shortest (0.15 seconds)	255		100%		FFh		0
		The Control channel should not be crossfaded. No shutter channel requirement.							
		Safe (normal operation)	0	15	0%	6%	00h	0Fh	
		Pan & Tilt speed Off	16	31	6%	12%	10h	1Fh	
15	Control	Display/LED's Off (send 20 packets)	32	47	13%	18%	20h	2Fh	0

	Display/LED's On (send 20 packets)	48	63	19%	25%	30h	3Fh
	Home All (send 20 packets)	64	79	25%	31%	40h	4Fh
	Shutdown (send 80 packets)	80	95	31%	37%	50h	5Fh
	TBD	96	255	38%	100%	60h	FFh

Error codes

When you turn on the fixture, it will make a reset at first. The display may show the "Err channel is XX" message while there are problems with one or more channels. "XX" stands for channel 1, 2, 3, 4, 5, 6 who has the testing sensor for positioning. For example, when the display shows "Err channel is Pan movement", it means there is some error in channel 1. If there are some errors on channel 1, channel 3, channel 11 at the same time, you may see the error message, "Err channel is Pan movement", "Err channel is Tilt movement", "Err channel is Shutter", flash repeated for 2 times, and then the fixture will generate a second reset. If the fixture error message remains after performing reset more than 2 times, only the channels which have errors cannot work properly, others can work as usual. Please contact with dealer or manufacturer for service, self-repair is not allowed.

PAN- movement Er

(PAN-yoke movement error) This message will appear after the reset of the fixture if the yoke's magnetic-indexing circuit malfunction (sensor failed or magnet missing) or the stepping-motor is defective (or its driving IC on the main PCB). The PAN-movement is not located in the default position after the reset.

TILT- movement Er

(TILT-head movement error) This message will appear after the reset of the fixture if the head's magnetic-indexing circuit malfunctions (sensor failed or magnet missing) or the stepping-motor is defective (or its driving IC on the main PCB). The TILT-movement is not located in the default position after the reset.